



V Style Ramp

In the Box:

- (1) – Ramp
- (2) – Ramp Hooks
- (4) – 5/16-18 x .625" Button Head
- (4) – .562" OD x .062 Thick Metal FW
- (4) – 5/16-18 Jam Nylok Nut

One of the following:

- QR/HD Mounting Hardware
- XD/SD Mounting Hardware

Tools Required:

- Security Wrench
- 1/2" Wrench
- 3/16" Allen Wrench

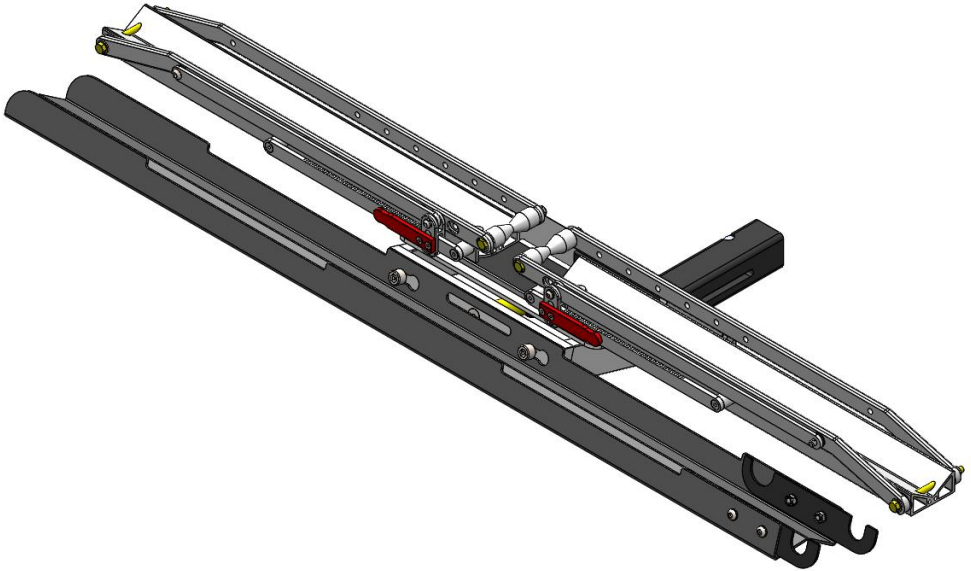

Product Notes:

- Compatible with Quik Rack, Heavy Duty, Super Duty, and Xtreme Duty Racks.
- Unit can install on driver or passenger side tray.
- Security Wrench required for assembly.

Assembly

1. Insert Button Head through Ramp and Ramp Hook. (Ramp Hook to be on inside of Ramp.)
2. Install Metal Washer and Jam Nylok Nut onto Button Head. Use 3/16" Allen Wrench and 1/2" wrench to tighten.
3. Repeat steps 1-3 for remaining holes.

QR/HD Rack Notes: Single Hook

XD Rack Notes: Use smaller hook side

SD Rack Notes: Use larger hook side

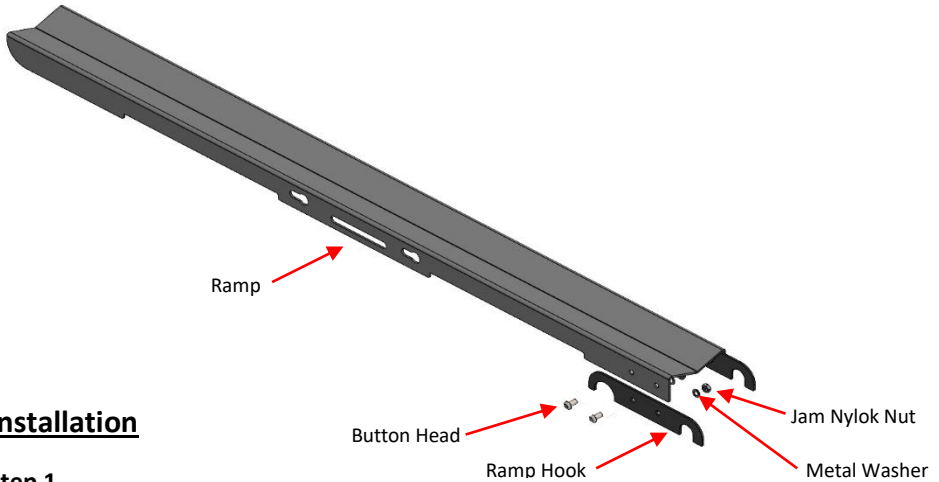

Installation

Step 1

Start Bolts in Tap Plate threaded holes.

XD/SD Rack: Spacer to be inserted between Tap Plate and Bolt

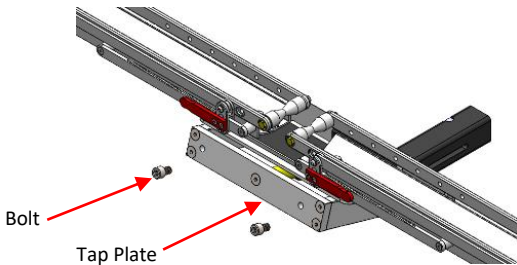

Place V Style Ramp onto base rack by aligning keyhole slots with Bolts. Tighten Bolts.

XD/SD Rack: Ramp will align between Spacer and Bolt Head

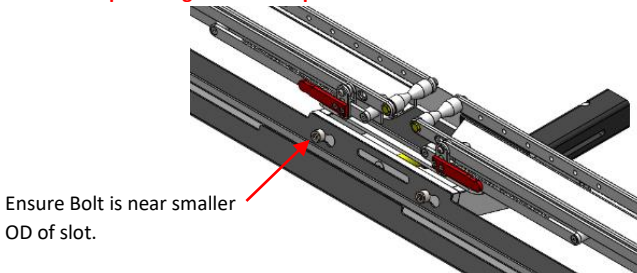

Step 2

Use 3/16" Allen Wrench and 1/2" Wrench to remove nut and bolt holding Strap to Bent Arm.

XD/SD Rack: Omit Step 2

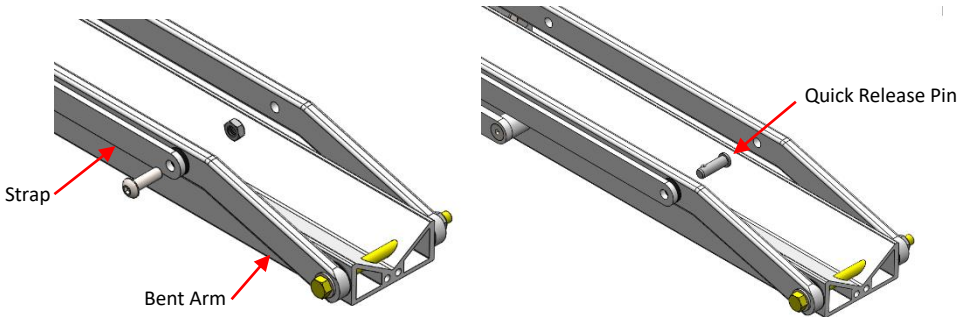

Install Quick Release Pin through Bent Arm, Spacer, and Strap.

Step 3

Remove 5/16-18 x 4.5" Hex Bolt from end of Tray. Install provided hardware in sequence shown below.

Note: Omit Step 3 for bike spots with fat tire spacer kits installed. (Ramp clips onto fat tire spacers.)

XD/SD Rack: Omit Step 3

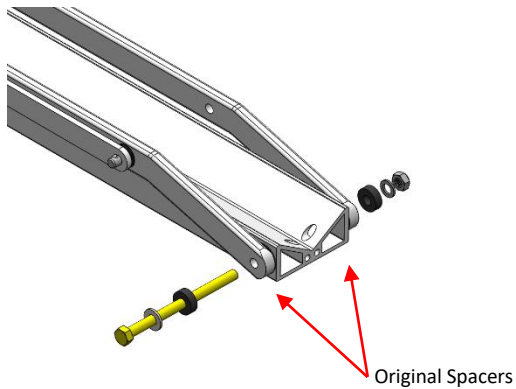

Loading Ramp

Step 1

Depress spring loaded release on Quick Release Pin and remove Strap from Pin. Pin will remain in bent arm.

XD/SD Rack: Omit Step 1

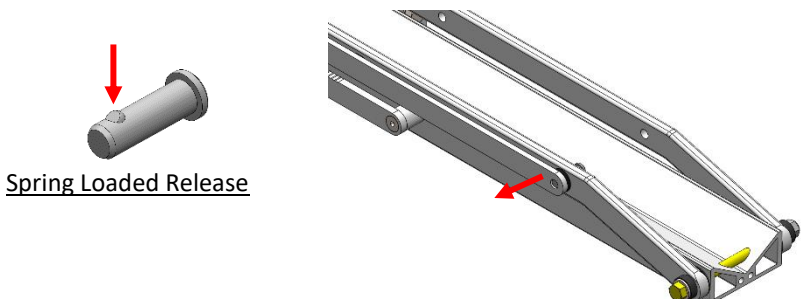

Step 2

Rotate Bent Arms so Spool is near ground. Ramp clips onto Plastic Spacers installed earlier (Step 3 - Installation).

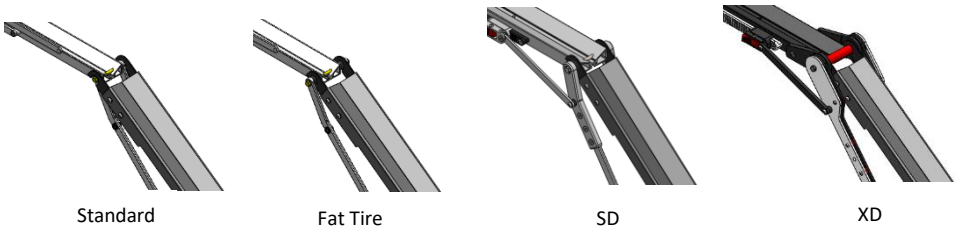

Step 3

Roll Bike up V Style Ramp and onto Rack Trays. Use Bent Arm, opposite of ramp, to stabilize bike while loading.

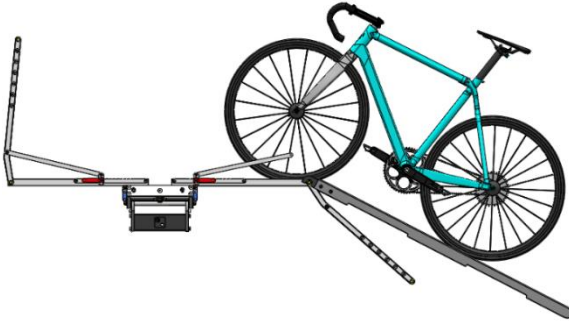

Step 4

Remove Ramp and install onto Tap Plate. If applicable reinstall Strap and Quick Release Pin. Pivot bent arms into tires firmly to secure bike.



Additional Instructions

- Remove road debris off nuts and bolts to prevent corrosion.
- Inspect hardware on Accessory periodically to ensure proper working conditions.
- Certain car wash chemicals may damage Accessory finish. Please use caution when cleaning vehicle and/or Accessory.

Questions or comments? Contact our support team via email at email@1up-usa.com



V Style Ramp Long

In the Box:

- (1) – Ramp
- (2) – Ramp Hooks
- (4) – 5/16-18 x .625" Button Head
- (4) – .562" OD x .062 Thick Metal FW
- (2) – 1/2-13 x 2.75" Socket Head
- (4) – 5/16-18 Jam Nylok Nut
- (1) – 3/8 x 5" Spring Pin
- (2) – Ramp Spacer

One of the following:

- QR/HD Mounting Hardware
- XD/SD Mounting Hardware

Tools Required:

- Security Wrench
- 1/2" Wrench
- 3/16" Allen Wrench

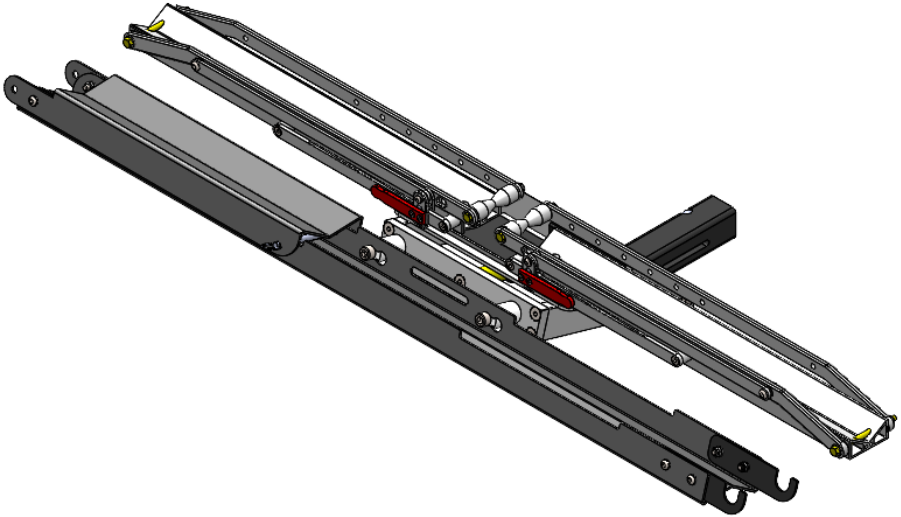

Product Notes:

- Compatible with Quik Rack, Heavy Duty, Super Duty, and Xtreme Duty Racks.
- Unit can install on driver or passenger side tray.
- Security Wrench required for assembly.
- Unit can be used opened or closed.

Assembly

1. Insert Button Head through Ramp and Ramp Hook. (Ramp Hook to be on inside of Ramp.)
2. Install Metal Washer and Jam Nylok Nut onto Button Head. Use 3/16" Allen Wrench and 1/2" wrench to tighten.
3. Repeat steps 1-3 for remaining holes.
4. Insert Spring Pin through Ramp holes.

QR/HD Rack Notes: Single Hook

XD Rack Notes: Use smaller hook side

SD Rack Notes: Use larger hook side

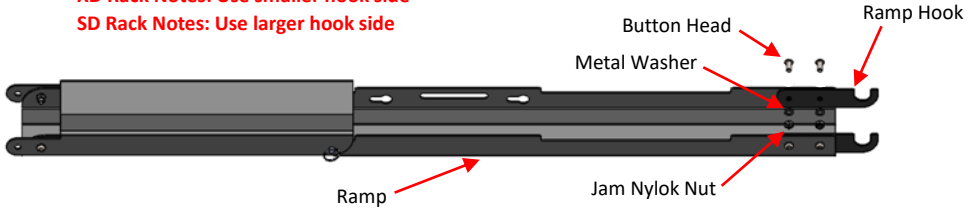

Closed



Open



Installation

Step 1

Start Socket Heads through Ramp Spacers into Tap Plate threaded holes.

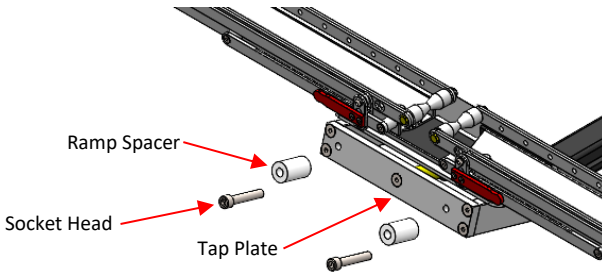

Place closed V Style Ramp Long onto base rack by aligning keyhole slots with Bolts. Tighten Bolts.

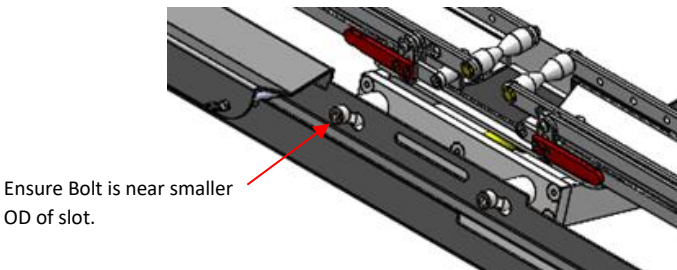

Step 2

Use 3/16" Allen Wrench and 1/2" Wrench to remove nut and bolt holding Strap to Bent Arm.

XD/SD Rack: Omit Step 2

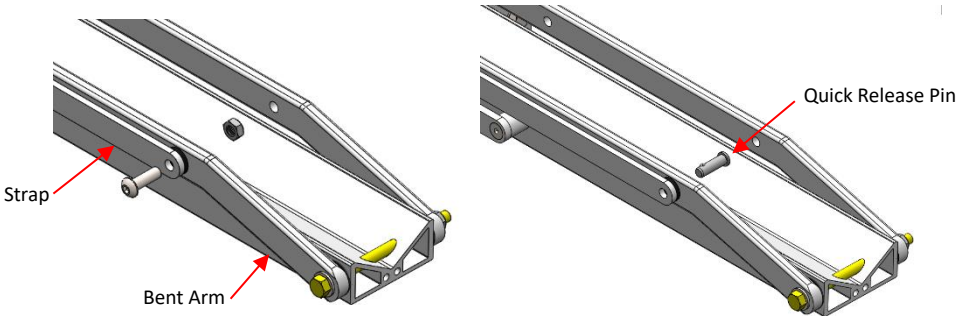

Install Quick Release Pin through Bent Arm, Spacer, and Strap.

Step 3

Remove 5/16-18 x 4.5" Hex Bolt from end of Tray. Install provided hardware in sequence shown below.

Note: Omit Step 3 for bike spots with fat tire spacer kits installed. (Ramp clips onto fat tire spacers.)

XD/SD Rack: Omit Step 3

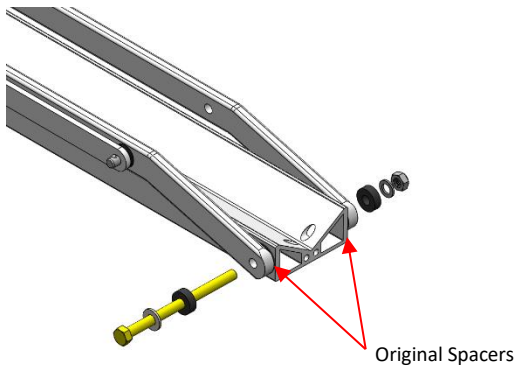

Loading Ramp

Step 1

Depress spring loaded release on Quick Release Pin and remove Strap from Pin. Pin will remain in bent arm.

XD Rack: Omit Step 1

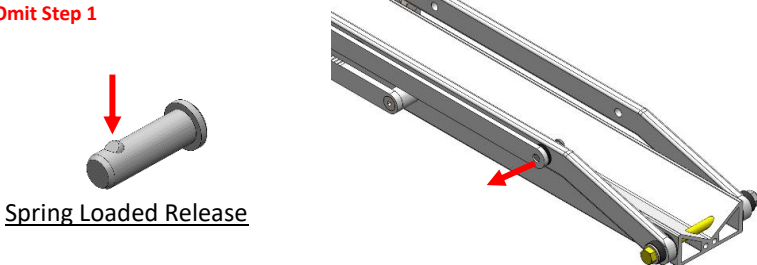

Step 2

Rotate Bent Arms so Spool is near ground. Remove Spring Pin and open Ramp. Insert Spring Pin into open position hole and clip Ramp onto Spacers (See below).

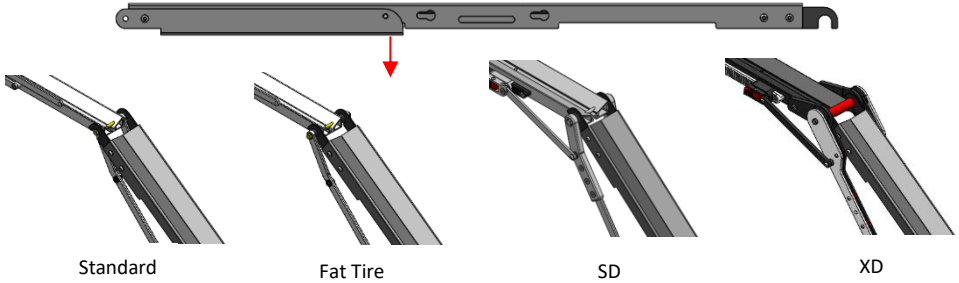

Step 3

Roll Bike up V Style Ramp Long and onto Rack Trays. Use Bent Arm, opposite of ramp, to stabilize bike while loading.



Step 4

Remove Spring Pin and close Ramp. Insert Spring Pin into closed position hole and install Ramp onto Tap Plate. If applicable reinstall Strap and Quick Release Pin. Pivot bent arms into tires firmly to secure bike.



Additional Instructions

- Remove road debris off nuts and bolts to prevent corrosion.
- Inspect hardware on Accessory periodically to ensure proper working conditions.
- Certain car wash chemicals may damage Accessory finish. Please use caution when cleaning vehicle and/or Accessory.

Questions or comments? Contact our support team via email at email@1up-usa.com